

# TK380

- Usage MR(Machine Room)
- Rated Load ~2,000kg(1:1)
- Elevator Speed ~6.0m/s
- Max Shaft Load 38,000kg
- Brake EC-4026EF DC90V/40V
- Weight 4100kg

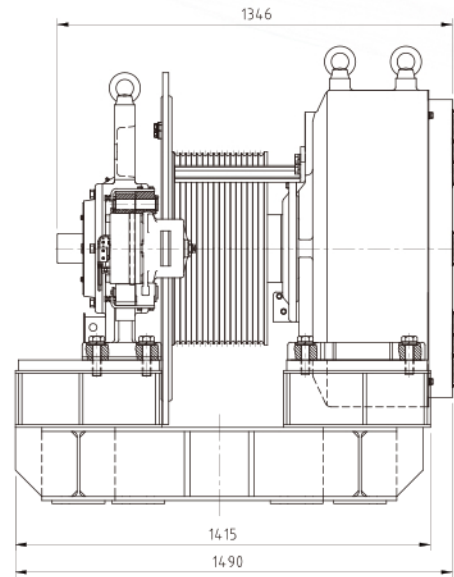
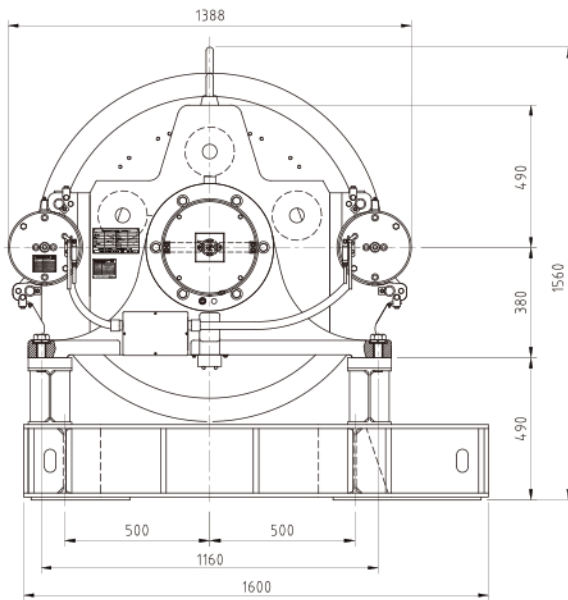
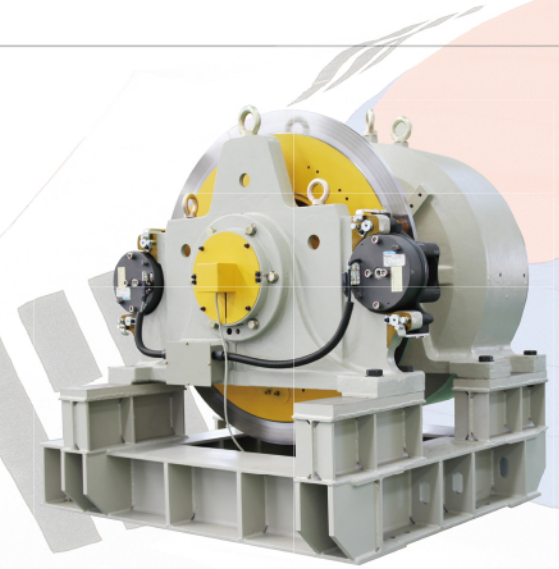

모델명 Model No.	속도 Speed (m/s)	정격하중 Rated load (kg)	시브 직경 Sheave Dia. (mm)	로프경 x 본수 Rope Dia. x QTY (Max.)	출력 Output (kW)	회전수 (rpm)	주파수 Frequency (Hz)	정격토크 Rated Torque (N·m)	정격전압 Voltage (V)	전류 Current (A)	로핑 Ropping	극수 Poles	절연등급 Insulation Class
TK380-347	3.0	1050	650	Φ16x8	34.7	88	26.4	3767	410	67.0	1:1	36	F
TK380-461	5.0				46.1	147	44.1	2995	420	72.1			
TK380-555	6.0				55.5	176	52.8	3011	415	88.2			
TK380-519	5.0	1800			51.9	147	44.1	3371	423	80.7			
TK380-624	6.0				62.4	176	52.8	3384	417	98.5			
TK380-578	5.0	2000			57.8	147	44.1	3756	426	89.6			
TK380-693	6.0				69.3	176	52.8	3761	420	109			