

TK150

- Usage MR(Machine Room)
- Rated Load ~1,600kg(2:1)
- Elevator Speed ~4.0m/s
- Max Shaft Load 15,000kg
- Brake EC-5415SM-C DC90V/40V
- Weight 1450kg

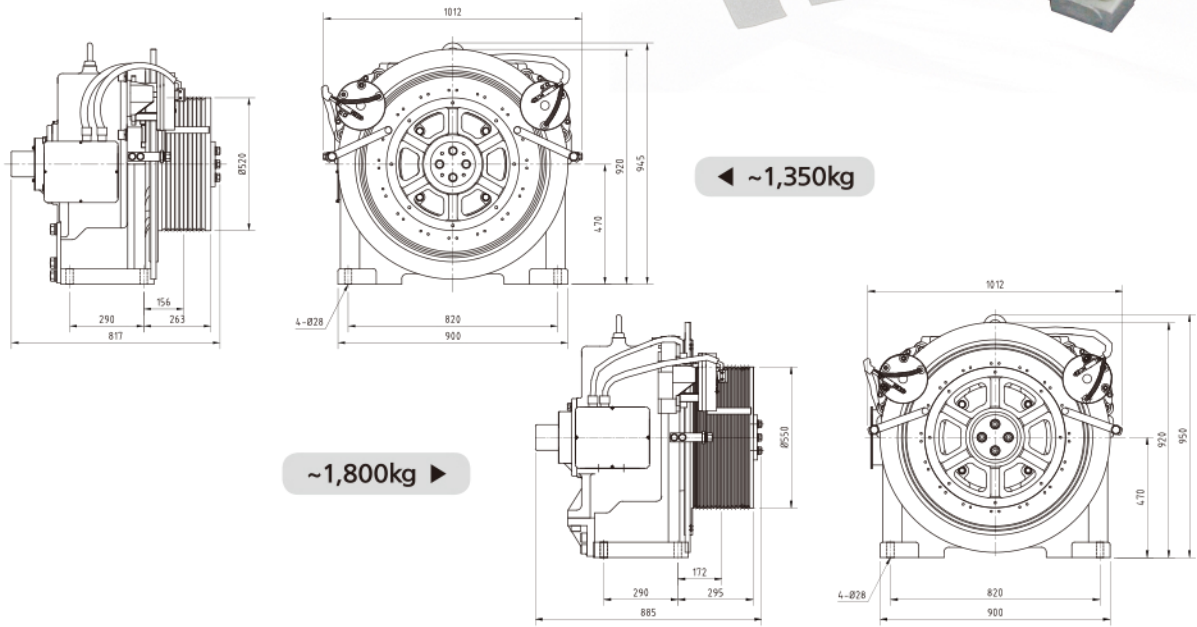
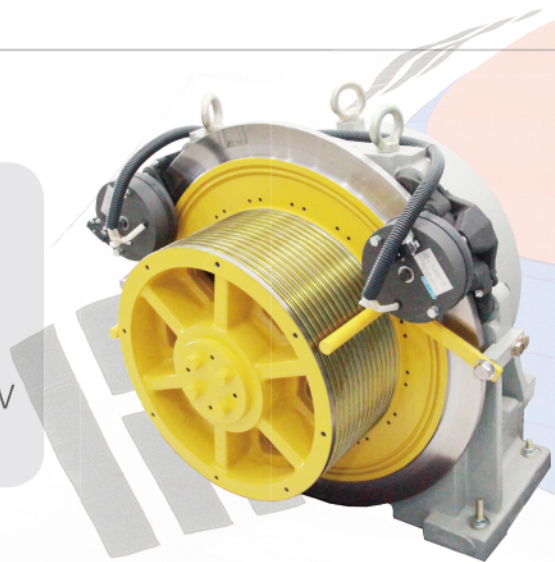

모델명 Model No.	속도 Speed (m/s)	정격하중 Rated load (kg)	시브 직경 Sheave Dia. (mm)	로프경 x 본수 Rope Dia. x QTY (Max.)	출력 Output (kW)	회전수 (rpm)	주파수 Frequency (Hz)	정격토크 Rated Torque (N-m)	정격전압 Voltage (V)	전류 Current (A)	로핑 Ropping	극수 Poles	절연등급 Insulation Class						
TK150-179	2.5	1150	520	Φ12x6 or Φ13x4	17.9	183	48.8	934	261	46.8	2:1	32	F						
TK150-215	3.0				21.5	220	58.7	933	312	47.0									
TK150-215S	3.0				21.5	220	58.7	933	267	55.0									
TK150-251	3.5				25.1	257	68.5	933	364	47.2									
TK150-286	4.0				28.6	294	78.4	929	355	55.3									
TK150-210	2.5	1350			520	Φ12x6 or Φ13x4	21.0	183	48.8	1096				267	54.7	2:1	32	F	
TK150-210S	2.5						21.0	183	48.8	1096				267	54.7				
TK150-252	3.0						25.2	220	58.7	1094				319	54.8				
TK150-252S	3.0						25.2	220	58.7	1094				273	64.2				
TK150-294	3.5						29.4	257	68.5	1093				372	55.0				
TK150-336	4.0	33.6	294	78.4			1090	363	64.5										
TK150-200	2.0	1600	550	Φ12x7 or Φ13x5			20.0	139	37.1	1375	247	57.1	2:1	32	F				
TK150-250	2.5						25.0	174	46.4	1372	307	57.1							
TK150-250S	2.5						25.0	174	46.4	1373	232	75.8							
TK150-300	3.0						30.0	209	55.6	1374	366	57.4							
TK150-300S	3.0				30.0	209	55.6	1374	277	76.1									
TK150-350	3.5				35.0	243	64.8	1377	322	76.5									
TK150-400	4.0				40.0	278	74.1	1374	367	76.8									
TK150-338	3.0				1800	550	Φ12x7 or Φ13x5	33.8	209	55.6	1546	374				64.5	2:1	32	F
TK150-393	3.5							39.3	243	64.8	1546	329				85.8			
TK150-450	4.0							45.0	278	74.1	1546	375				86.1			