

TK150

- Usage MR(Machine Room)
- Rated Load ~3,000kg(2:1)
- Elevator Speed ~4.0m/s
- Max Shaft Load 15,000kg
- Brake EC-5415SM-C DC90V/40V
- Weight 1390kg

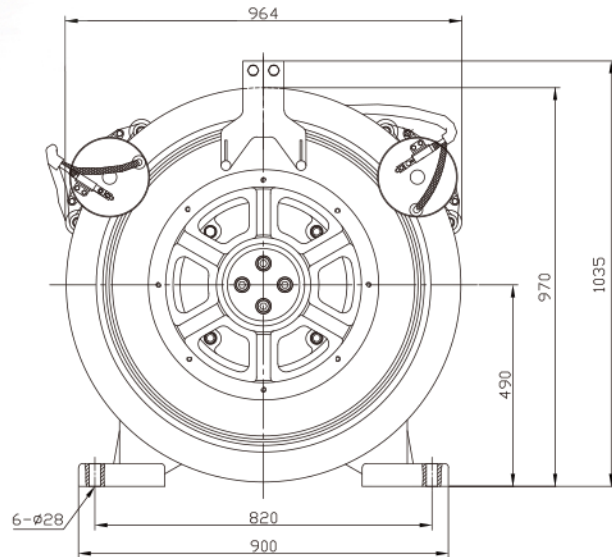
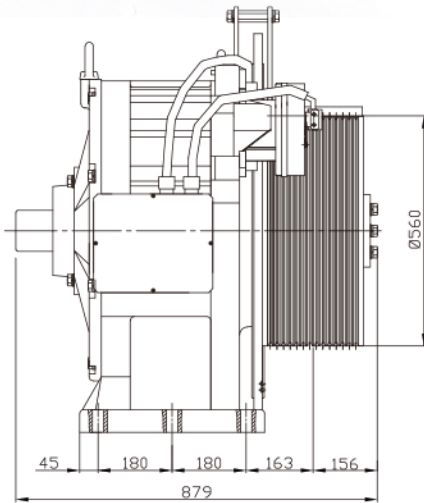

모델명 Model No.	속도 Speed (m/s)	정격하중 Rated load (kg)	시브 직경 Sheave Dia. (mm)	로프경 x 본수 Rope Dia. x QTY (Max.)	출력 Output (kW)	회전수 (rpm)	주파수 Frequency (Hz)	정격토크 Rated Torque (N-m)	정격전압 Voltage (V)	전류 Current (A)	로핑 Ropping	극수 Poles	절연등급 Insulation Class
TK150-245	2.0	2000	560	φ12x7	24.5	136	36.4	1716	284	61.6	2:1	32	F
TK150-307	2.5				30.7	171	45.5	1719	353	62.0			
TK150-368	3.0				36.8	205	54.6	1717	275	94.5			
TK150-429	3.5				42.9	239	63.7	1715	320	94.7			
TK150-490	4.0				49.0	273	72.8	1715	364	95.0			
TK150-089	0.5	3000	480		8.9	40	10.6	2137	208	35.1			
TK150-178	1.0				17.8	80	21.3	2126	195	70.0			
TK150-266	1.5				26.6	119	31.9	2135	285	70.5			
TK150-355	2.0				35.5	159	42.5	2131	377	70.6			